

Tanaka Illustrated Parts Manual

Model Number:

THT-2100

HEDGETRIMMER

P/N 27123

Rev 002

Date 9-17-08



Nikko Tanaka Engineering U.S.A.,Ltd. • 1028 4th Street SW, Bldg B • Auburn, WA 98001 • Phone: (253) 333-1200 • Fax: (253) 333-1212

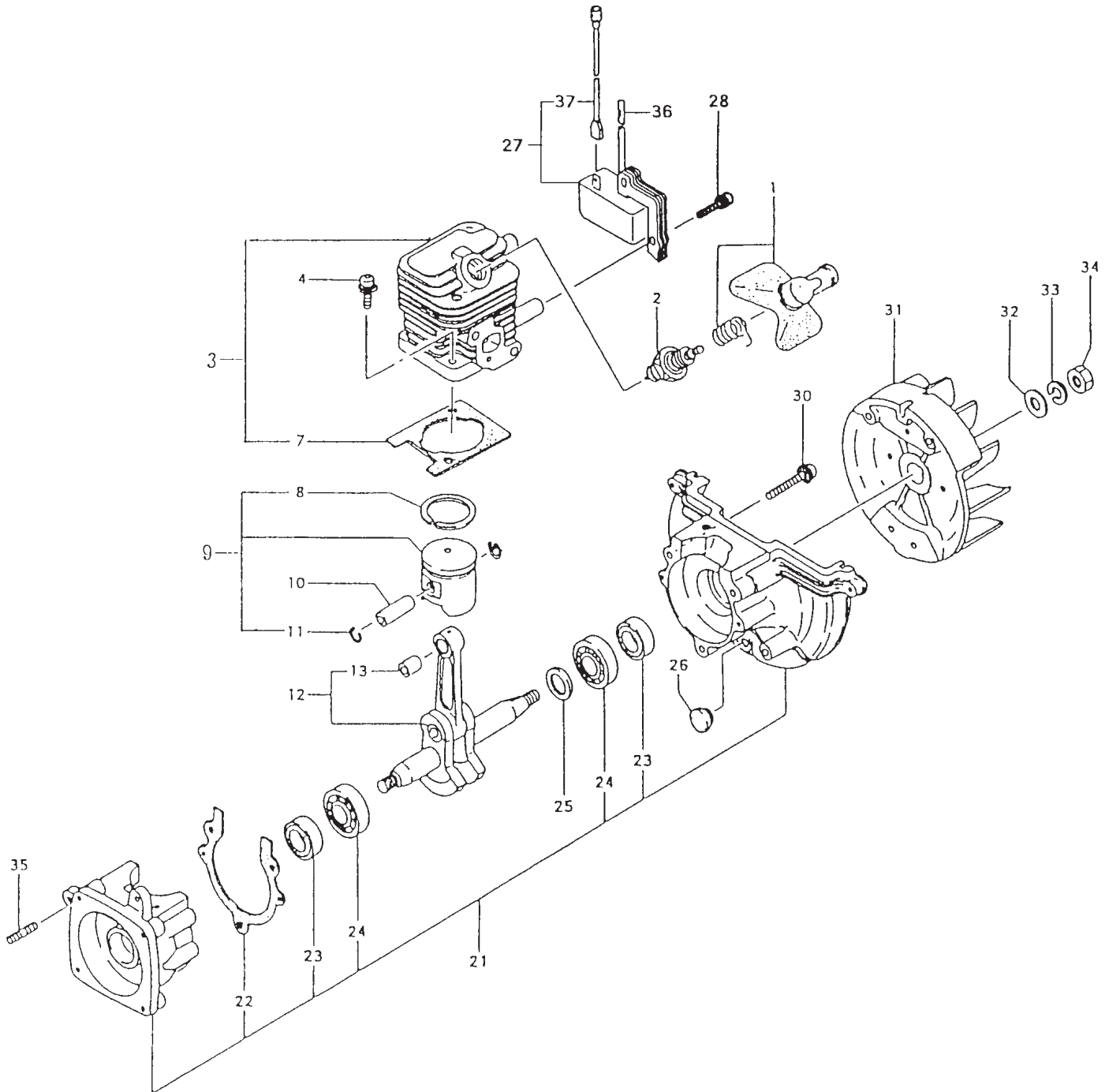

ENGINE / CYLINDER, PISTON, CRANKSHAFT • FIGURE 1

ITEM	PART NUMBER	DESCRIPTION	QTY	COMMENTS
1-1	1570650091	CAP, SPARK PLUG ASS'Y	1	
1-2	01804075200	PLUG, SPARK	1	
1-3	0010650090	SET, CYLINDER	1	Includes cylinder gasket
1-4	99416050201	SCREW, 5X20/WS	2	
1-7	0170650020	GASKET, CYLINDER	1	
1-8	04100601210	RING, PISTON	1	
1-9	0300650090	SET, PISTON	1	Includes rings, and circlips
1-10	03706500200	PIN, PISTON	1	
1-11	03901620200	CIRCLIP, PISTON PIN	2	
1-12	04606500801	CRANKSHAFT	1	
1-13	99962081225	BEARING, NEEDLE, F-810	1	
1-21	0720650090	CRANKCASE ASS'Y	1	Crankcase assy includes bearings, seals and gasket.
1-22	09006500200	GASKET, CRANKCASE	1	
1-23	99966122206	SEAL, OIL, #TC12227	2	
1-24	99961600100	BEARING, BALL, #6001	2	
1-25	33000200210	SHIM, 12.2X19X.10	V	Shims are "as needed" to obtain correct side clearance
1-25	33000200220	SHIM, 12.2X19X.15	V	
1-25	33000200230	SHIM, 12.2X19X.20	V	
1-25	33000200240	SHIM, 12.2X19X.30	V	
1-26	59900601200	CUSHION	1	
1-27	1672153280	COIL, IGNITION	1	
1-28	99416040226	SCREW, WS, 4X22	2	
1-30	99414050301	SCREW, 5X30/S	3	
1-31	1552152380	ROTOR, MAGNETO	1	
1-32	99201080011	WASHER, 8	1	
1-33	99210080012	WASHER, S, 8	1	
1-34	99101080011	NUT, 8	1	
1-35	10002100200	BOLT, STUD, 6X22	2	
1-36	25006500200	TUBE, INSULATOR	1	
1-37	1780650080	CORD, STOP COMPLETE	1	

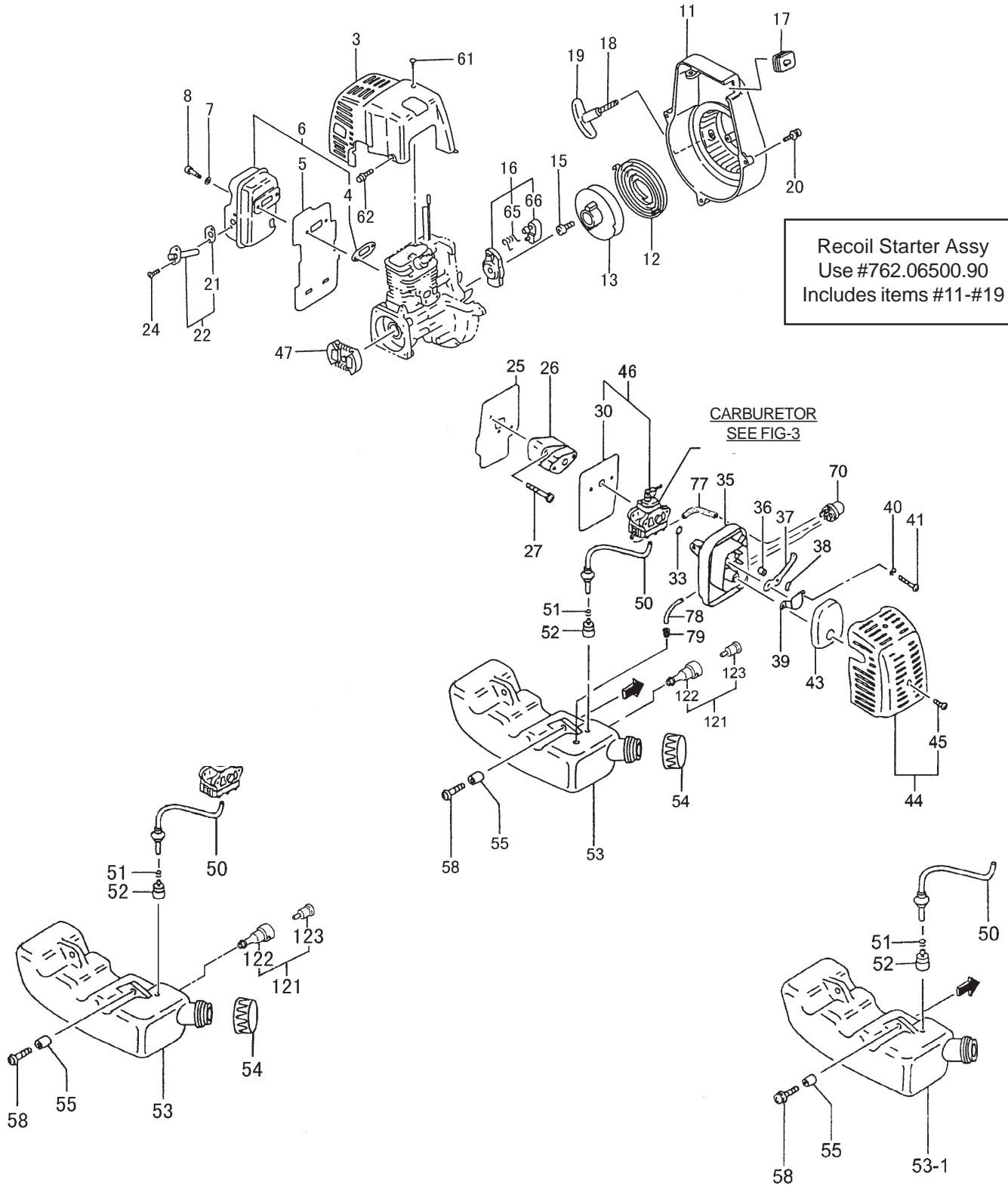

ITEM	PART NUMBER	DESCRIPTION	QTY	COMMENTS
2-3	7380650020	PROTECTOR,MUFFLER	1	
2-4	73706500200	GASKET,MUFFLER	1	
2-5	13306500200	SHIELD,HEAT	1	
2-6	7040651C90	MUFFLER,SET	1	
2-7	99201050011	WASHER,5	2	
2-8	99051050503	BOLT,HEX,5X50	2	
2-11	1120650080	CASE,FAN	1	
2-12	78006097200	SPRING,RECOIL	1	
2-13	77406097200	PULLEY,STARTER	1	
2-15	8390201020	SCREW,SET	1	
2-16	79806500900	PULLEY,STARTER,ASSY	1	
2-17	2030604A202	GROMMET	1	
2-18	78306097200	ROPE,STARTER	1	
2-19	78506410200	HANDLE,STARTER	1	
2-20	99415040162	SCREW,PS,4X16	3	
2-21	75106500200	GASKET,MUFFLER	1	
2-22	7210650090	PIPE,TAIL	1	
2-24	99434040081	SCREW,4X8/S	2	
2-25	40306500200	GASKET,INTAKE	1	
2-26	4040650090	SET,CARB INSULATOR	1	Includes carburetor gasket
2-27	99416050252	SCREW,5X25WS	2	
2-30	40206500200	GASKET,CARBURETOR	1	
2-33	99967015000	O-RING,P15	1	
2-35	4230650081	BODY,CLEANER	1	
2-36	47006500200	COLLAR	2	
2-37	5280650T20	LEVER,CHOKE	1	
2-38	99204080030	WASHER,8	1	
2-39	47601700200	BOARD,BLOW OVER CHECK	1	
2-40	99210050012	WASHER,S,5	2	
2-41	99011050602	SCREW,5X60	2	
2-43	4460650020	ELEMENT,CLEANER	1	
2-44	4520650091	COVER,CLEANER W/BOLT	1	
2-45	3800637C200	BOLT,CLEANER COVER	1	
2-47	2770634F900	CLUTCH,ASSY	1	

ITEM	PART NUMBER	DESCRIPTION	QTY	COMMENTS
2-50	2230650090	PIPE,FUEL,ASS'Y	1	
2-51	68000731201	CLIP 6.3	1	
2-52	6750404280	FILTER,FUEL	1	
2-53	5910650000	TANK.FUEL	1	Before S/N T245720
2-53	5910661321	TANK.FUEL		S/N T245721 to U244200
2-53	5910651A21	TANK,FUEL	1	S/N U244201 and after
2-54	5950650A90	TANK CAP	1	Before S/N T245720
2-54	5950656B90	CAP,FUEL BLACK,NON VENT	1	S/N T245271 and after
2-55	65900801200	COLLAR	2	
2-58	99463050185	BOLT,HEX 5X18PS	2	
2-61	99072045164	SCREW,TAPPING,4.5X16	1	
2-62	99425040128	BOLT,PS,4X12	2	
2-65	79006097200	SPRING,STARTER PAWL	1	
2-66	7880650020	PAWL,STARTER	1	
2-70	44225143800	PUMP,PRIMING ASS'Y	1	S/N U244201 and after
2-77	70002504080	PIPE,FUEL,2.5X4X80	1	S/N U244201 and after
2-78	7000250406	PIPE,FUEL,2.5X4X65	1	S/N U244201 and after
2-79	53432710200	GROMMET,FUEL PIPE	1	S/N U244201 and after
2-121	56400661190	VENT,AIR ASS'Y	1	
2-122	5650441020	PIPE,AIR VENT	1	
2-123	5640098190	AIR VENT VALVE ASSY	1	

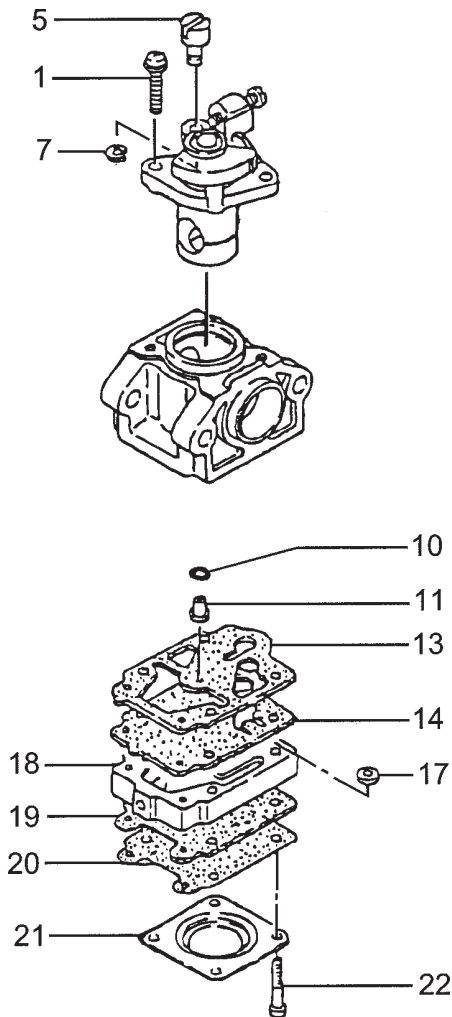

A small retainer (560-02170-20), has been added to this model after serial # A099801 to prevent the barrel end of the throttle wire from coming detached from the carburetor.

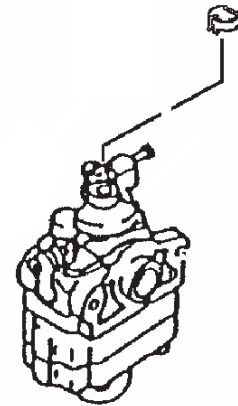

ITEM	PART NUMBER	DESCRIPTION	QTY	COMMENTS
3-0	4550650090	CARBURETOR,SET	1	Before S/N U244200
3-0	4550651A90	CARBURETOR	1	S/N U244201 and after
3-1	54825140200	SCREW,THROTTLE SET	1	
3-5	53925120200	SWIVEL	1	* Contained in Carb Repair Kit
3-7	48925100200	RING,STOP	1	P/N 650-25124-900 (Not available individually)
3-10	55025100200	O-RING	1	
3-11	5992000W35	JET,MAIN,#35	1	Before S/N U244200
3-11	599200BW34	JET,MAIN,LONG,#34.5	1	S/N U244201 and after
3-13	~ ~ ~	*GASKET,PUMP	1	
3-14	~ ~ ~	*DIAPHRAGM,PUMP	1	
3-17	~ ~ ~	*SCREEN,INLET	1	
3-18	5752518280	BODY,PUMP	1	Before S/N U244200
3-18	5752514780	BODY,PUMP ASS'Y	1	S/N U244201 and after
3-19	~ ~ ~	*GASKET,DIAPHRAGM	1	Before S/N U244200
3-19	~ ~ ~	*GASKET,DIAPHRAGM	1	S/N U244201 and after
3-20	~ ~ ~	*DIAPHRAGM,METERING	1	
3-21	47625004200	COVER,DIAPHRAGM	1	
3-22	54825101200	SCREW,SET	4	

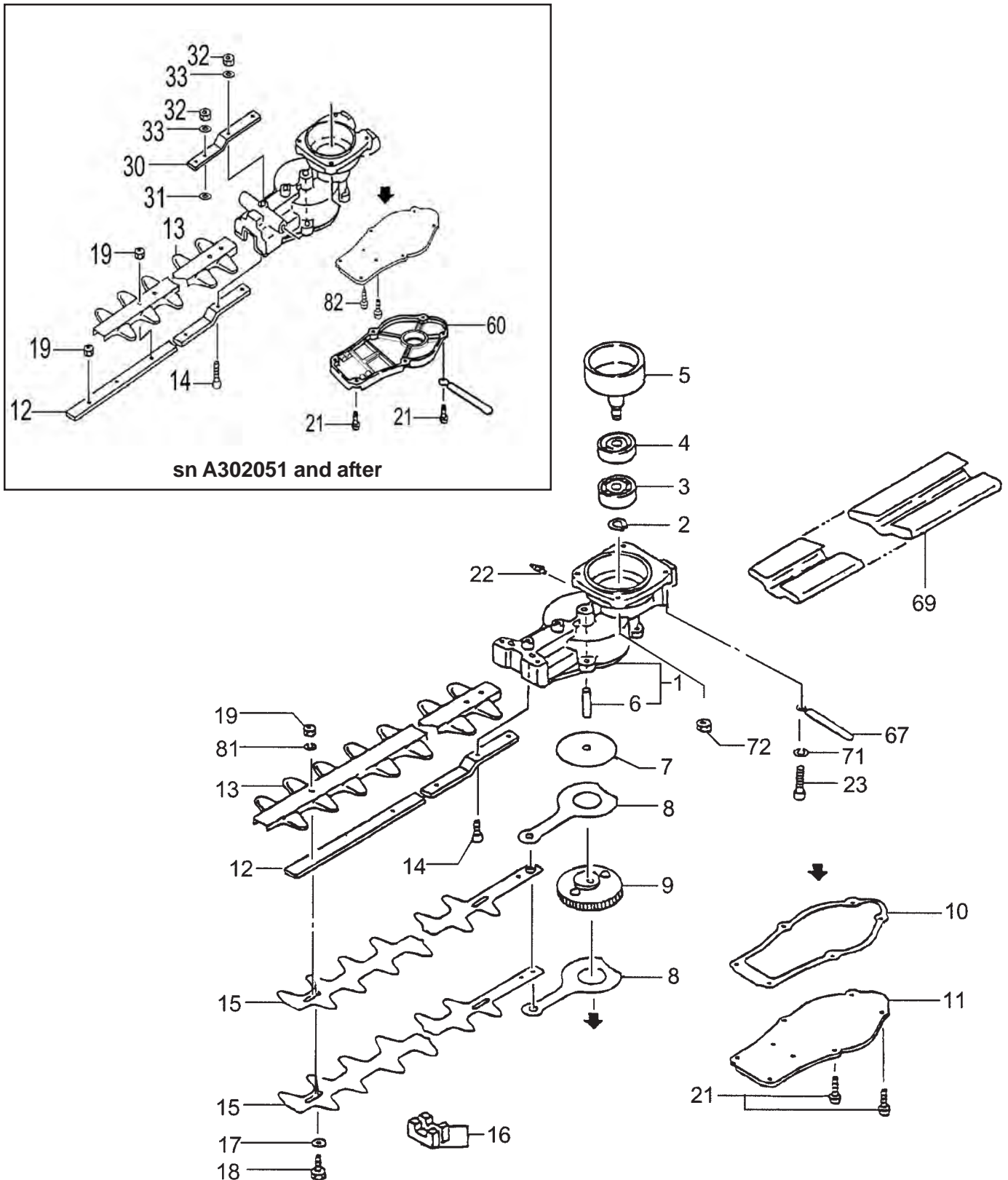

GEAR CASE, CUTTER BLADES • FIGURE 4

ITEM	PART NUMBER	DESCRIPTION	QTY	COMMENTS
4-1	3003317A80	CASE,GEAR	1	
4-2	99350015002	RING,STOP,C-15 EX	1	
4-3	99961600200	BEARING,BALL,#6002	1	
4-4	99961600202	BEARING,BALL,#6002Z	1	
4-5	2883318080	DRUM,CLUTCH	1	
4-6	30533160200	SHAFT,GEAR	1	
4-7	07533160200	PLATE,GUIDE	1	
4-8	1013316022	ROD,CAM	2	
4-9	3073318020	GEAR,2	1	
4-10	30333160200	GASKET,GEARCASE	1	
4-11	6303316020	COVER,GEAR CASE	1	
4-12	1223316021	GUIDE,CUTTER 625MM	1	~A302050
4-12	1223317820	GUIDE,CUTTER	1	A302051~
4-13	1363316020	PLATE,PROTECTION	1	S278771~
4-14	99052060165	BOLT,HEX,6X16	2	~A302050
4-14	99052060255	BOLT,HEX FLUSH,6X25	2	A302051~
4-15	CB-21A	BLADE,CUTTER,THT-210/2100	2	
4-16	08533160200	SEAL,GREASE A	2	
4-17	12933202201	WASHER,7	4	
4-18	1243320221	BOLT,CUTTER FIXING,A	4	~A302050
4-18	1243228720	BOLT,FIXING,A,M6	4	A302051~
4-19	1233317A20	NUT,CUTTER FIXING	4	Y004401 thru A302050
4-19	40927	NUT,FLANGE,6	3	A302051~
4-21	99461040104	BOLT,HEX,4X10,S	8	~A302050
4-21	99461040124	BOLT,HEX,4X12,S	6	A302051~
4-22	30032250801	FITTING,GREASE	2	
4-23	99051060143	BOLT,HEX,6X14	2	
4-30	4623329520	PLATE,SUPPORT	1	A302051~
4-31	8713260020	WASHER SPECIAL A	1	A302051~
4-32	99187060001	NUT	3	A302051~
4-60	3013316021	GEAR CASE B	1	A302051~
4-67	19805015800	CLAMP,CORD	1	
4-69	13833160200	COVER,CUTTER,22"	1	~S278770
4-69	1383316820	COVER,CUTTER,22"	1	S278771~
4-71	99210060012	WASHER,S,6	2	
4-72	99440060011	NUT,SPRING 6	2	
4-81	99201060011	WASHER,6	3	S278771~
4-82	99461040104	BOLT,HEX,4X10,S	2	A302051~

HANDLE, THROTTLE LEVER • FIGURE 5

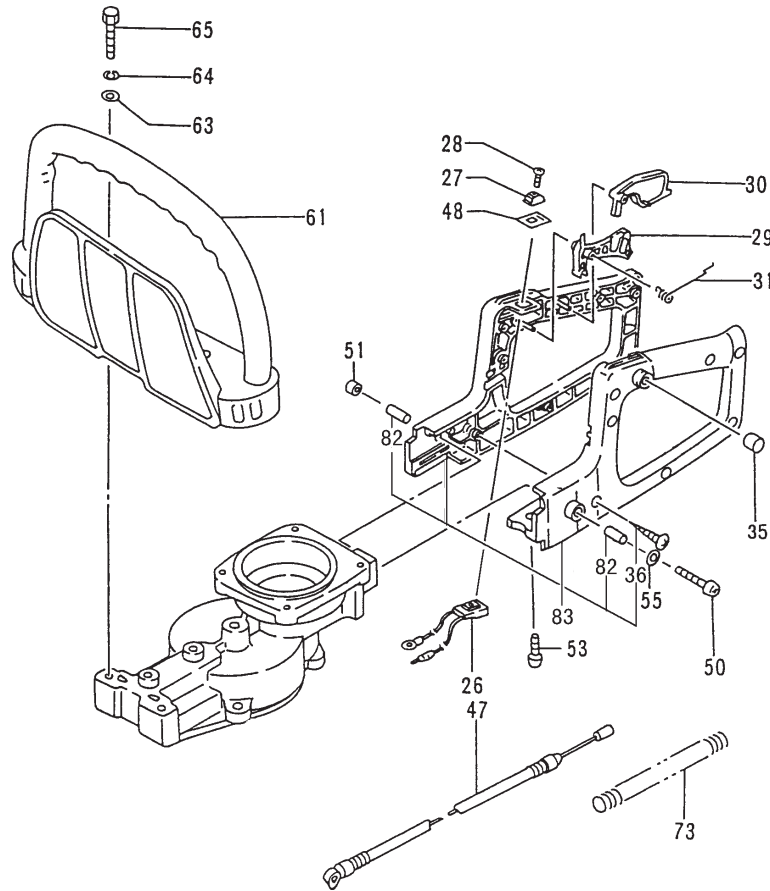

ITEM	PART NUMBER	DESCRIPTION	QTY	COMMENTS
5-26	1703317A80	SWITCH,STOP	1	
5-27	2581165020	BUTTON,STOP	1	
5-28	99011030101	SCREW,3X10	1	
5-29	2303315020	LEVER,THROTTLE	1	
5-30	23133150200	LEVER,SAFETY	1	
5-31	23233150200	SPRING,THROTTLE LEVER	1	
5-35	7653212020	CAP	1	
5-36	99311040182	SCREW,TAPPING 4x18	7	
5-47	8850651C80	WIRE,THROTTLE	1	
5-48	9253253020	DECAL,STOP BUTTON	1	
5-50	99414050451	SCREW,5X45/S	1	
5-51	99178050010	NUT,LOCK 5	1	
5-53	99414060181	SCREW,6X18/S	1	
5-55	99200050011	WASHER,SMALL,5	1	
5-61	2103316021	HANDLE	1	
5-64	99210050062	WASHER,S,5	2	
5-63	3683205720	WASHER,5	2	
5-65	99051050403	BOLT,HEX,5 X 40	2	
5-73	1640701400	TUBE, PROTECTION 140L	1	
5-82	65900801200	COLLAR	2	
5-83	05033150010	HANDLE ASS'Y	1	Includes both left and right handles

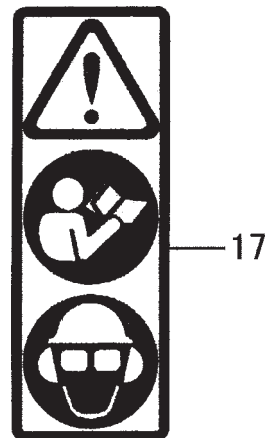
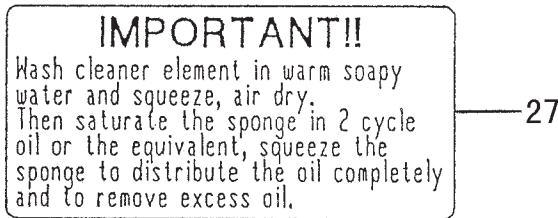
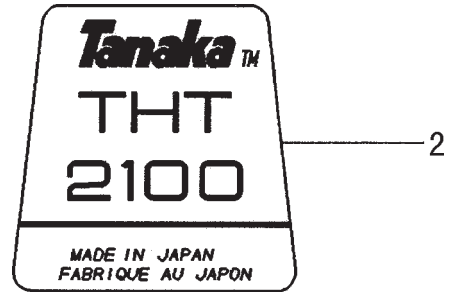

ITEM	PART NUMBER	DESCRIPTION	QTY	COMMENTS
6-1	95037900200	DECAL, PRO-FORCE A	1	
6-2	9060651C20	DECAL, THT-2100	1	
6-5	95137900200	DECAL, PRO-FORCE	1	
6-8	91106500200	DECAL, SRS	1	
6-17	9203246620	DECAL, CAUTION	1	
6-27	9083316021	DECAL, CAUTION	1	

Date: June 2001

Model & Serial: THT-2100/THT-2120/THT-2510/THT-2520/THT-2540/HTD-2522PF/HTD-2526PF/HTD-2530PF/HTS-2530PF.

All units produced after serial number W100101.

Reason: When these units are fitted with the aluminum safety shield, some experience loosening of the blade jam nuts. A flat washer has been added between the nut and the aluminum shield to help prevent the nut from becoming loose.

Models THT-2100, 2120, 2510 and HTD-2526PF, 2522PF require 3 washers.

Models THT-2520, 2540 and HTS-2530PF and HTD-2530PF require 2 washers

Part Number Changes:

Old Part #	New Part #	Description	Remarks
992-01060-011		Washer	

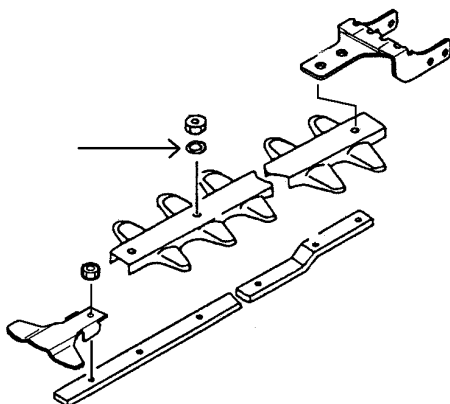

Date: January, 2002

Model & Serial: All THT, HTD, HTS, TPH hedgetrimmer models.

All units after serial number Y004401

Reason: All future production of hedgetrimmer models will utilize a blade-retaining nut that is of the locking variety. These nuts are oblong on one side to prevent loosening during use, but can be removed and re-installed without losing their locking ability.

When adjusting blade-fastening hardware, thread the bolt (18) through the blades and guide bar from the bottom, to a point where the flat washer (17), is still able to rotate, (usually to seat, and then backed off between 1/4 and 1/2 revolution). Then install the lock nuts on the topside, tightening them while holding the bolt in place. Tighten all nuts, and then re-check for adjustment prior to operation. A lubricating agent, such as WD-40 should also be used to prevent sap build-up and premature wear.

Part Number Changes:

Old Part #	New Part #	Description	Remarks
123-33202-200	123-3317A-20	Lock Nut	Reference #19

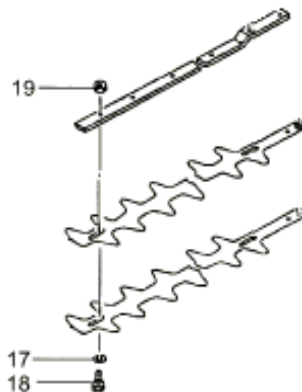

Date: December 2004

Model & Serial: THT-2100
A302051 and later

Reason: Configuration standardization of hardware, converting blade hardware from US Standard thread to Metric thread. An additional support plate is also being added to this product to strengthen the cutter guide.

Comments: Please verify serial number on unit prior to ordering replacement blade hardware and add the support plate on older serial numbers. The support plate qualifies for warranty reimbursement at .25 hours and normal parts rate.

Part Number Changes:

Description	Old parts #	New parts #
Cutter guide 625.5L M6 (#12)	122-33160-21	122-33178-20
Cutter fixing bolt A	124-33202-21	124-32287-20
Flange nut M6 (#19)	123-3317A-20	991-82060-001
Hex hole flush bolt 6x255 (#14)	990-52060-165	990-52060-255
Protection plate 390L (#13)	136-33160-20	
Washer 6 (#33)	992-01060-011	Keep same pcs & reuse some for protection plate
Hex hole bolt 4x10S (#82)		994-61040-104
Hex hole bolt 4x12S (#21)	994-61040-104	994-61040-124
Special washer B 2.0 (#31)		871-32600-200
Gear case B (#60)		301-33160-21
Support plate (#30)		462-33295-20
Nut 6 UPS-P (#32)		991-87060-001
Front handle	210-33160-21	210-33160-22

